



Peerless, Inc.

Water Conditioning Equipment

1701 E. Vine St., P.O. Box 3615, Kalamazoo, MI 49003-3615
Phone: (269) 344-6137 Fax: (269) 344-2894

Operation & Maintenance Manual

CME Series FME-W Series Water Softeners



INSTALLATION DIAGRAM Peerless CME Series and FME-W Series Softeners

Specifications:

Rough in dimension - From the floor to the center of bypass approximately 50".

Maximum distance and size for Drain line: 50' horizontal, 10" vertical rise, using 1/2" ID drain line.

Maximum distance and size for brine line: 15' horizontal, (see note), using 1/4" ID poly tubing.

Note: The horizontal distance for the brine tank can be increased to 35' if the brine tank is installed above the unit.

Example: Softener installed in the basement and brine tank installed on 1st floor. The brine tank CANNOT be installed below bottom of unit. The drain and brine lines should NOT be installed with tubing that can collapse. This will cause the unit to malfunction.

Caution: Do NOT connect drain line tubing from control valve to overflow fitting/tubing on brine tank. ^

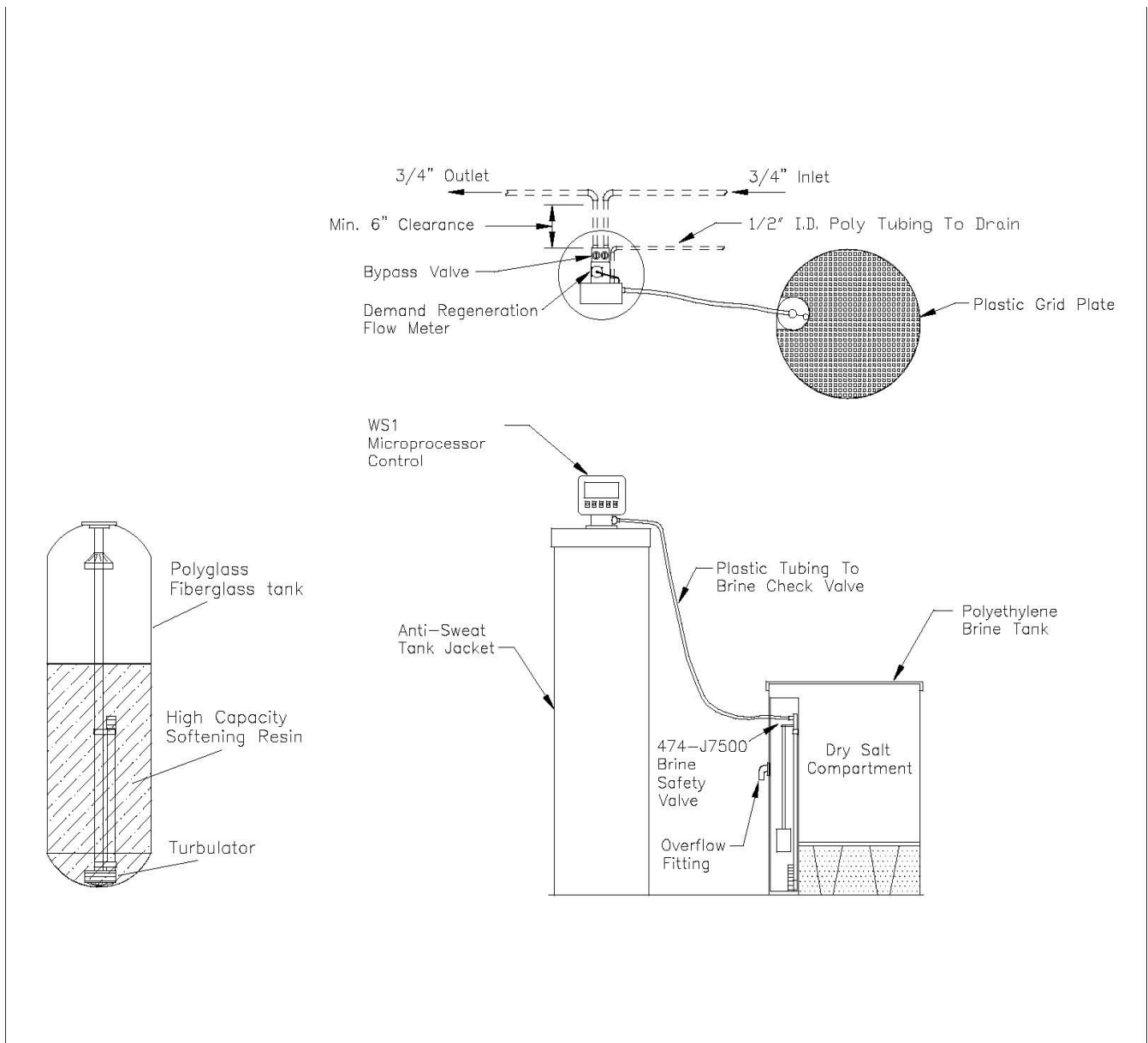

INSTALLATION DIAGRAM Peerless CME (C) Series and FME-W (C) Series Softeners

Specifications:

Rough in dimension - From the floor to the center of bypass approximately 50".

Maximum distance and size for Drain line: 50' horizontal, 10" vertical rise, using 1/2" ID drain line.

Maximum distance and size for brine line: 15' horizontal, (see note), using 1/4" ID poly tubing.

Note: The horizontal distance for the brine tank can be increased to 35' if the brine tank is installed above the unit.

Example: Softener installed in the basement and brine tank installed on 1st floor. The brine tank CANNOT be installed below bottom of unit. The drain and brine lines should NOT be installed with tubing that can collapse. This will cause the unit to malfunction.

Caution: Do NOT connect drain line tubing from control valve to overflow fitting/tubing on brine tank.

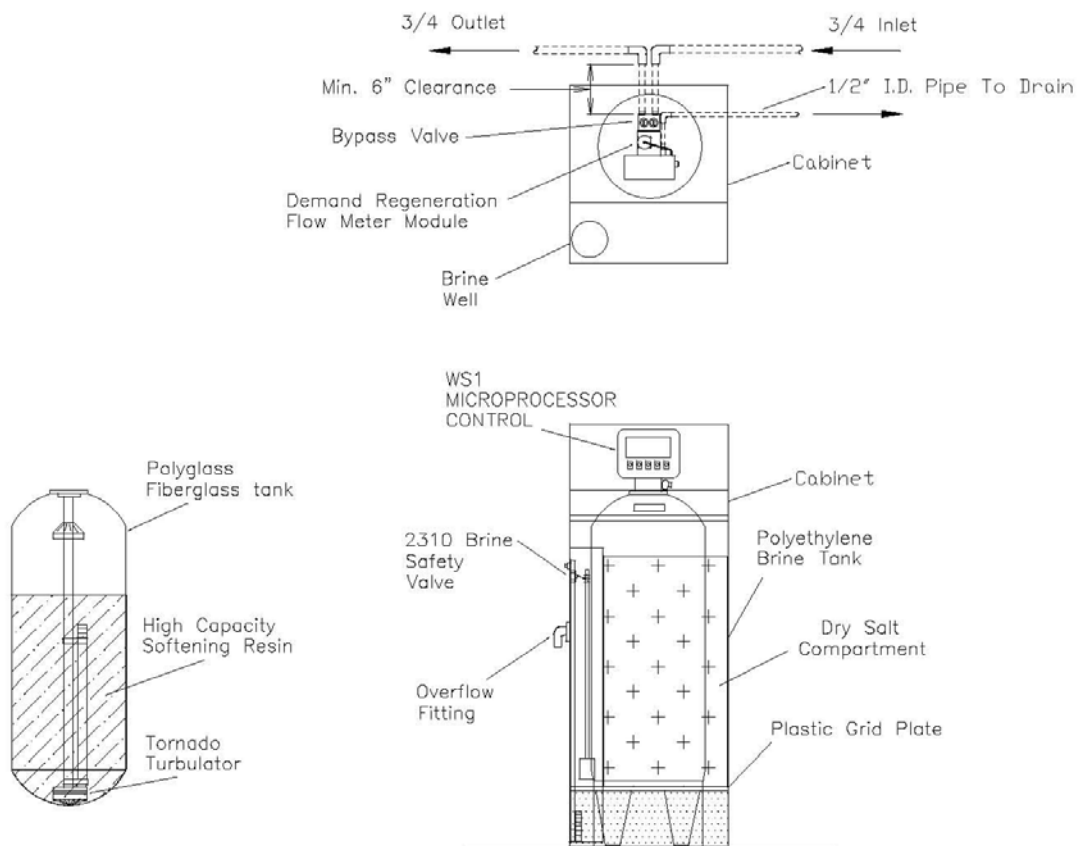

Start-up Procedure Peerless CME (C) and FME-W (C) Series Softeners

- 1 Pipe ¾" or 1" inlet and outlet service piping, according to the print, and arrows on bypass.
- 2 Set brine tank in place on a clean, level surface. This prevents bottom puncture when weight of water and salt are added. Connect brine line (furnished in brine tank) from brine tank to valve. Line must be air tight.
- 3 Connect 5/8" OD poly tubing (not supplied) from valve to suitable drain. DO NOT use clear collapsible tubing.
- 4 With bypass valve in the bypass position, open a cold water tap nearby and let it run a few minutes. Once free from air, close tap. Partly open bypass to allow water to slowly fill tank. Once water stops running into tank, rotate bypass valve into full service position. Again, open a cold water tap nearby and let the water run until the water is clear and free of air.
- 5 Plug unit into an approved 120V AC outlet. Press the Set Clock button once and the hour will flash. Press the Up or the Down triangle buttons until the correct hour is displayed. Press the Set Clock button again, and the minutes will flash. Use the Up or the Down triangle buttons until the correct minutes are displayed. Press the Set Clock button again to finish. **NOTE:** Time of day must be set correctly to either AM or PM.
- 6A Test water, and set computed grains of hardness expressed as gpg (grains per gallon), and iron expressed as ppm (parts per million). Iron 0.1 - 1.0 ppm add 4 grains; 1.1 - 2 ppm add 8 grains; 2.1 - 3.0 ppm add 12 grains; 3.1 - 4 ppm add 16 grains; and 4.1 - 5.0 ppm add 20 grains. Add it to the hardness value. This is the total compensated hardness and the number you will use to set up the unit. Once you have your total hardness and compensated iron results, divide that number by the capacity of the unit. Example: 30 FME-W, or 30 CME is a 30,000 grain unit; 30,000 divided by 25 grains (hardness & compensated iron) = 1,200 gallons.
NOTE: If your iron result is higher than 2 ppm for the FME-W or 5 ppm for the CME, we recommend an iron filter be installed before the softener. If an iron filter is installed, you do not need to compensate for any iron.
- B To set gallons in the unit, press the Next and Up triangle buttons at the same time. The display will show gallons. Press the Up or Down triangle to enter your gallons, from the results in step 6A.
- C Press the Next button, and the display will show Regen Day. The factory default is set at 7 for the CME, and 15 for the FME-W. Please do not change this value.
- D Press the Next button and the display will show the Regen Time. The factory default is set at 2:00 AM. Press the Up or Down triangle to change the hour. Press the Next button and the minutes will flash. Press the Up or Down triangle to change the minutes. Press the Next button to finish. **NOTE:** All regeneration cycle times are Pre-programmed.
- 7 Manually add water to brine tank until water is 1/2" above the grid.
- 8A Press and hold the Regen button for 5 seconds. Release when the display shows backwash. Let the water run for 5 minutes
 - B Press the Regen button and release. The display will show Brine. Wait 1 minute.
 - C Press the Regen button and release. The display will show Backwash. Wait 1 minute.
 - D Press the Regen button and release. The display will show Rinse. Wait 1 minute.
 - E Press the Regen button and release. The display will show Fill. Push down on the float rod to purge air from the brine line.
- 9 Fill brine tank with salt. Peerless recommends Pro Soft, Hardi-Cube, Dura-Cube or Mini-Cube or salt substitutes, i.e. Potassium Chloride, (trade names) K-Life or Soft Touch. These are recommended for their high solubility and pureness.
- 10 Open cold water valves in house to relieve air. Let water run for 3 minutes and test cold water to make sure it is soft.
- 11 Hot water from the water heater (unless drained and filled with soft water) will not become soft until the customer has used approximately 3 times the holding capacity of the water heater.
- 12 Write the installation date (month/year) on the sticker found inside the front cover.

Installer Display Settings

Volume (Gallons) selected in Configuration Settings

Step 1I



Step 2I

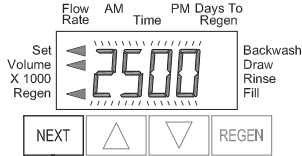

Step 3I

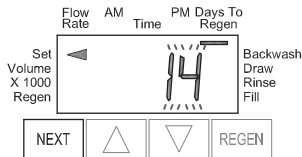

Step 4I

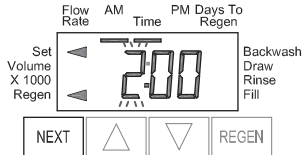

Step 5I

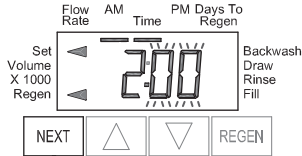

EXIT TO
DISPLAY
SCREENS

Step 1I - To enter Installer Display press NEXT and ▲ simultaneously for 5 seconds and release.

Step 2I - Volumetric capacity in gallons to regeneration. Press NEXT to go to Step 3I. Press REGEN to exit Installer Display.

Step 3I - Adjust day override from 1 - 28 or OFF. Press NEXT to go to Step 4I. Press REGEN to return to previous step.

Step 4I - Use ▲ or ▼ to set the regen hour. Press NEXT to go to Step 5I. Press REGEN to return to the previous step.

Step 5I - Use ▲ or ▼ to set the regen minutes. Press NEXT to exit Installer Display. Press REGEN to return to previous step.

Regeneration and Error Screens

Regen Screen

Displays the time remaining in the current cycle. Pressing REGEN advances to the next cycle.

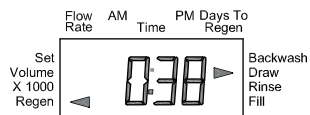

Error Screen

Alternated flashing Err and error code every 3 seconds. Clear by disconnecting the power supply at the PC board and reconnecting, or press the NEXT and REGEN simultaneously for 3 seconds.

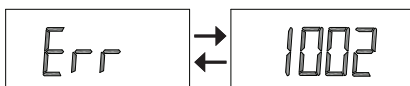

In Alternator Systems when a unit is waiting to initiate the first cycle step of regeneration, "REGEN PndG" is displayed.

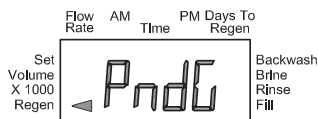

"STbY" is displayed in Alternator Systems when a valve is in Standby state.

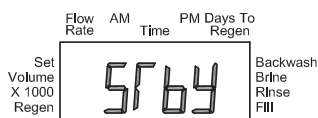

"REGEN PndG RINSE FILL" is displayed whenever a zero-capacity tank has transferred to an off-line state and is currently waiting to initiate the second portion of a regeneration cycle. Viewed only when Delayed Rinse and Fill is set to ON.

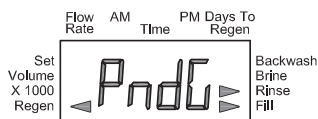

Button Operation and Function



Scrolls to the next display.

Pressing once and releasing will schedule a regeneration at the preset delayed regeneration time.

Pressing again and releasing will cancel the regeneration.



Pressing and holding for 3 seconds will initiate an immediate regeneration

Pressing while in regeneration will advance to the next cycle.

Pressing in the program levels will go backwards to the previous screen



Changes variable being displayed.



Key sequence to lock and unlock program settings.

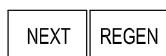

Holding for 3 seconds initiates a control reset. The software version is displayed and the piston returns to the home/service position, resynchronizing the valve.

Regeneration Cycles and Times

Cycle	Range of times (min.)	
	Softening	Filtering
1. Backwash 1 st (upflow)	1 - 95	1 - 95
2. Regenerant Draw/Slow Rinse (downflow)	1 - 180	N/A
3. Backwash 2 nd (upflow)	1 - 95	N/A
4. Fast Rinse (downflow)	1 - 95	1 - 95
5. Regenerant Refill (with treated water)	0.1 - 99.9 or OFF	N/A
6. Service (downflow)		

The user can initiate manual regeneration. The user has the option to request the manual regeneration at the delayed regeneration time or to have the regeneration occur immediately:

- Pressing and releasing REGEN. "◀" will flash towards Regen on the display and the regeneration will occur at the delayed regeneration time. The user can cancel the request by pressing and releasing REGEN.
- Pressing and holding REGEN for approximately 3 seconds will immediately start the regeneration. The user cannot cancel this request, except by resetting the control by pressing NEXT and REGEN simultaneously for 3 seconds.

User Displays

General Operation

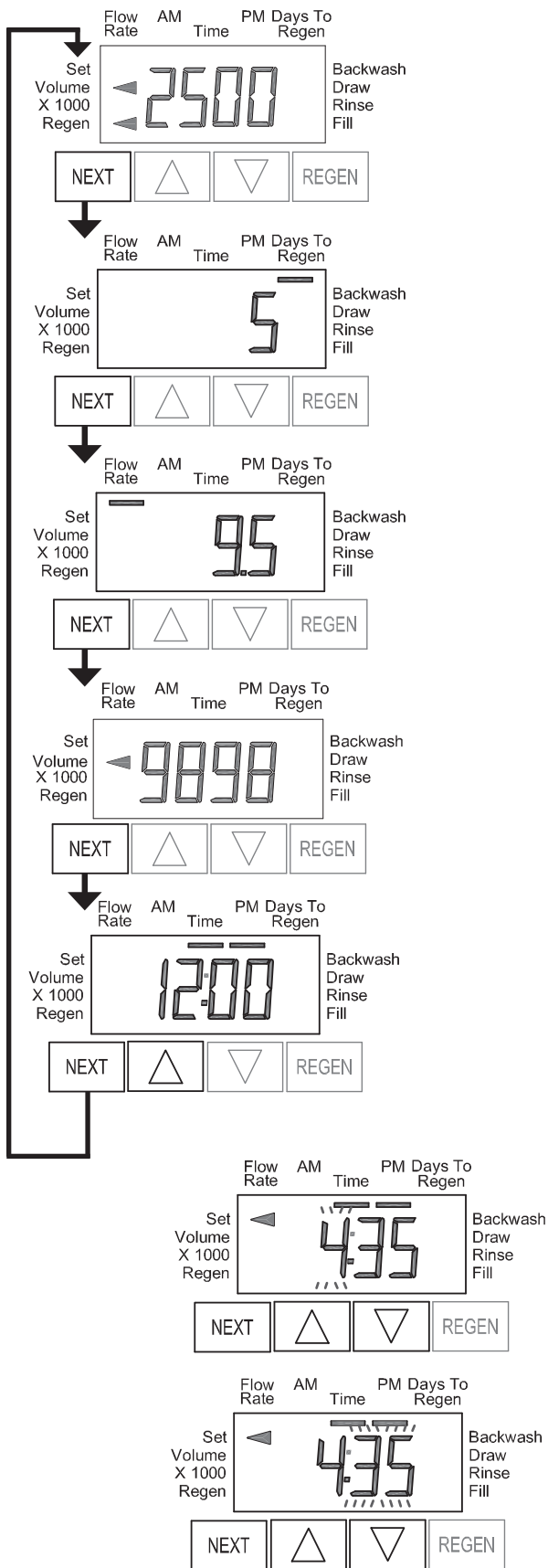

When the system is operating, one of five displays may be shown. Pressing NEXT will alternate between the displays shown below.

User 1

Typical user display. If volume is selected in Configuration Settings Step 4CS, shows volume remaining to regeneration. If volume is not selected in Configuration Settings Step 4CS, this screen will not be shown. If a meter is not used this display will not change.

User 2

Displays number of days to next regeneration.

User 3

Displays flow rate in gallons per minute. If a meter is not used this display will be shown but 0 will be displayed. If 1.0F is selected in Step 2CS an "A" in front of the flow rate indicates that the tank with the control valve on it is in service. If "b" is displayed the tank with the in/out head is in service. This screen will not be shown if 7 day or 28 day is selected in Configuration Settings Step 4CS.

User 4

Displays total flow in gallons since last reset. If a meter is not used this display will be shown but 0 will be displayed. This screen will not be shown if 7 day or 28 day is selected in Configuration Settings Step 4CS.

PRESS ▼ FOR 3 SECONDS TO RESET TO 0.

User 5

Shows current time.

Setting Time of Day

Push NEXT until time of day screen is displayed. Press and hold ▲ or ▼ until the SET indicator is displayed, and the hour flashes. Press ▲ or ▼ until the correct hour is displayed.

Then press NEXT. The minutes will flash. Press ▲ or ▼ until the correct minute is displayed.

Press NEXT to return to the Display Screens. Time of day should only need to be set after power outages lasting more than 8 hours, if the battery has been depleted and a power outage occurs, or when daylight saving time begins or ends. If a power outage lasting more than 8 hours occurs, the time of day will flash on and off which indicates the time of day should be reset. If a power outage lasts less than 8 hours and the time of day flashes on and off, the time of day should be reset and the battery replaced.

Diagnostics

Step 1D



Step 2D

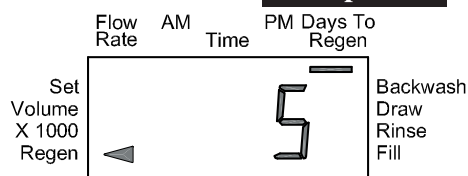

Step 3D

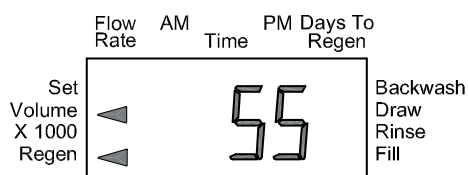

Step 4D

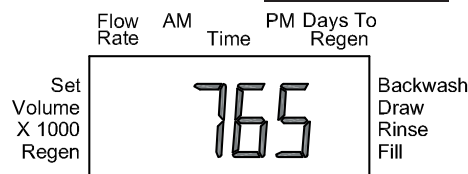

Step 5D

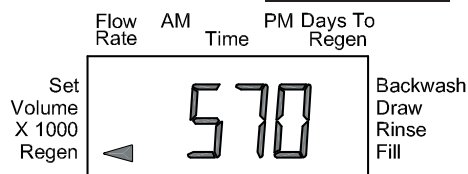

EXIT TO
DISPLAY
SCREENS

Step 1D - Press ▲ and ▼ simultaneously for 5 seconds and release. Then press ▲ and ▼ simultaneously for 3 seconds and release. If screen in Step 2D does not appear the lock on the valve is activated. To unlock press ▼, NEXT, REGEN, ▲ in sequence, then press ▲ and ▼ simultaneously for 5 seconds and release. Then press ▲ and ▼ simultaneously for 3 seconds and release.

Step 2D - Display shows the number of days since a regeneration last occurred. Press NEXT to go to Step 3D. Press REGEN to exit Diagnostics.

Step 3D - Display shows the volume of water treated in gallons treated since the last regeneration. If Volume (gallons), 28/Volume (gallons), or 7/Volume (gallons) was selected in Step 4CS and no meter is installed this display will read 0. Press NEXT to go to Step 4D. Press REGEN to return to previous step.

Step 4D - Display shows the days in service since start up. Press NEXT to go to Step 5D. Press REGEN to return to previous step.

Step 5D - Display shows the total number of regeneration cycles since start up. Press NEXT to exit Diagnostics. Press REGEN to return to previous step.

BYPASS VALVE

The bypass valve is typically used to isolate the control valve from the plumbing system's water pressure in order to perform control valve repairs or maintenance. The W100SM bypass valve is particularly unique in the water treatment industry due to its versatility and state of the art design features.

The 1" full flow bypass valve incorporates four positions including a diagnostic position that allows service personnel to work on a pressurized system while still providing untreated bypass water to the facility or residence. It's completely non-metallic, all plastic design allows for easy access and serviceability without the need for tools. The bypass body and rotors are glass filled Noryl and the nuts and caps are glass filled polypropylene. All seals are self-lubricating EPDM to help prevent valve seizing after long periods of nonuse. Internal o-rings can easily be replaced if service is required. The bypass consists of two interchangeable plug valves that are operated independently by red arrow shaped handles. The handles identify the flow direction of the water. The plug valves enable the bypass valve to operate in four positions.

Normal Operation Position: The inlet and outlet handles point in the direction of flow indicated by the engraved arrows on the control valve. Water flows through the control valve during normal operation and this position also allows the control valve to isolate the media bed during the regeneration cycle. (See figure 17)

Bypass Position: The inlet and outlet handles point to the center of the bypass, the control valve is isolated from the water pressure contained in the plumbing system. Untreated water is supplied to the plumbing system. (See figure 18)

Diagnostic Position: The inlet handle points in the direction of flow and the outlet handle points to the center of bypass valve, system water pressure is allowed to the control valve and the plumbing system while not allowing water to exit from the exiting current constant and moving a permanent magnet near the semiconductor produces a voltage output proportional to the movement of the magnet. Hall-effect devices provide a high-speed response, excellent temperature stability and no physical contact.** Has not been tested for compliance with California Proposition 65 so this control valve to the plumbing. (See figure 19)

Shut-Off Position: The inlet handle points to the center off the bypass valve and the outlet handle points in the direction of flow; the water is shut off to the plumbing systems. If water is available on the outlet side of the softener it is an indication of water bypass around the system (i.e. a plumbing connection somewhere in the building bypasses the system). (See figure 20)

BYPASS VALVE DIAGRAMS

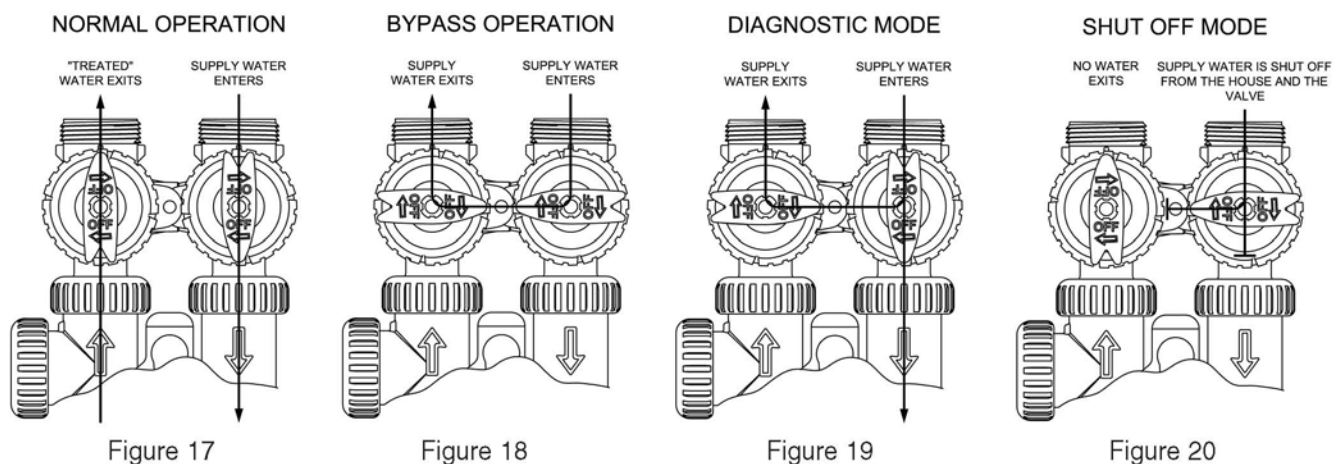

SERVICE INSTRUCTIONS

DRIVE ASSEMBLY

Remove the valve cover to access the drive assembly.

Disconnect the power source plug (black wire) from the PC board prior to disconnecting the motor or water meter plugs from the PC board. The motor plug connects to the two-pin jack on the left-hand side of the PC board. The power source plug connects to the four-pin jack. The four-pin jack is between the two-pin and three-pin jacks. The water meter plug (gray wire) connects to the three.

The PC board can be removed separately from the drive bracket but it is not recommended. Do not attempt to remove the display panel from the PC board. Handle the board by the edges. To remove the PC board from the drive bracket, unplug the power, water meter and motor plugs from the PC board. Lift the middle latch along the top of the drive bracket while pulling outward on the top of the PC board. The drive bracket has two plastic pins that fit into the holes on the lower edge of the PC board. Once the PC board is tilted about 45° from the drive bracket it can be lifted off of these pins. To reinstall the PC board, position the lower edge of the PC board so that the holes in the PC board line up with the plastic pins. Push the top of the PC board towards the valve until it snaps under the middle latch, weave the power and water meter wires into the holders and reconnect the motor water meter and power plugs.

The drive bracket must be removed to access the drive cap assembly and pistons or the drive gear cover. It is not necessary to remove the PC board from the drive bracket to remove the drive bracket. To remove the drive bracket start by removing the plugs for the power source and the water meter. Unweave the wires from the side holders. Two tabs on the top of the drive back plate hold the drive bracket in place. Simultaneously lift the two tabs and gently ease the top of the drive bracket towards your body. The lower edge of the drive bracket has two notches that rest on the drive back plate. Lift up and outward on the drive bracket to disengage the notches. To reassemble seat the bottom of the drive bracket so the notches are engaged at the bottom of the drive back plate. Push the top of the drive bracket towards the two latches. The drive bracket may have to be lifted slightly to let the threaded piston rod pass through the hole in the drive bracket. Maintain a slight engaging force on top of the drive bracket while deflecting the bracket slightly to the left by pressing on the side of the upper right corner. This helps the drive gears mesh with the drive cap assembly. The drive bracket is properly seated when it snaps under the latches on the drive back plate. If resistance is felt before latching, then notches are not fully engaged, the piston rod is not in hole, the wires are jammed between the drive bracket and drive back plate, or the gear is not engaging the drive cap assembly.

To inspect drive gears, the drive gear cover needs to be removed. The drive gear cover is held in place on the drive bracket by three clips. The largest of the three clips is always orientated to the bottom of the drive bracket. Before trying to remove the drive gear cover, the drive bracket must be removed from the drive back plate. The drive gear cover can be removed from the drive bracket without removing the motor or the PC board. Simultaneously, push in and down on the large clip at the bottom and the clip on the left-hand side of the drive bracket behind the PC board. Keep your other fingers behind the drive gear cover so the drive gears do not drop on the ground. Replace broken or damaged drive gears. Do not lubricate any of the gears. Avoid getting any foreign matter on the reflective coating because dirt or oils may interfere with pulse counting.

The drive gear cover only fits on one way, with the large clip orientated towards the bottom. If all three clips are outside of the gear shroud on the drive bracket the drive gear cover slips easily into place.

The drive bracket does not need to be removed from the drive plate if the motor needs to be removed. To remove the motor, disconnect the power and motor plugs from the jacks on the PC board. Move the spring clip loop to the right and hold. Rotate the motor at least a ½ turn in either direction before gently pulling on the wire connections to remove the motor. Pulling directly on the wire without rotating the motor may break the wires off the motor.

Replace the motor if necessary. Do not lubricate the motor or the gears. When reinstalling the motor gently turn the motor while inserting so that the gear on the motor meshes with the gears under the drive gear cover and the small plastic bulge engages one of the slots on the motor housing. Reconnect the motor plug to the two-pronged jack on the lower left-hand side of the PC board. If the motor will not easily engage with the drive gear when reinstalling, lift and slightly rotate motor before reinserting.

SERVICE INSTRUCTIONS CONTINUED

Replace the valve cover. After completing any valve maintenance, press and hold NEXT and REGEN buttons for 3 seconds or unplug power source jack (black wire) and plug back in. This resets the electronics and establishes the service piston position. The display should flash all wording, then flash the software version (e.g. 154) and then reset the valve to the service position.

DRIVE CAP ASSEMBLY, MAIN PISTON AND REGENERANT PISTON

The drive assembly must be removed to access the drive cap assembly. The drive cap assembly must be removed to access the piston(s). The drive cap assembly is threaded into the control valve body and seals with an o-ring. To remove the drive cap assembly, use the special plastic wrench or insert a 1/4" to 1" flat bladed screwdriver into one of the slots around the top 2" of the drive cap assembly so it engages the notches molded into the drive back plate around the top 2" of the piston cavity. See Figure 5. The notches are visible through the holes. Lever the screwdriver so the drive cap assembly turns counter clockwise. Once loosened unscrew the drive cap assembly by hand and pull straight out. The drive cap assembly contains the drive cap, the main drive gear, drive cap spline, piston rod and various other parts that should not be disassembled in the field. The only replaceable part on the drive cap assembly is the o-ring. Attached to the drive cap assembly is the main piston (downflow or upflow) and if a regenerant is used, a regenerant piston. The regenerant piston (the small diameter one behind the main piston) is removed from the main piston by unsnapping it from its latch. Chemically clean in dilute sodium bisulfite or vinegar and replace the regenerant piston if needed. To remove the main downflow or upflow piston fully extend the piston rod and then unsnap the main piston from its latch by pressing on the side with the number. Chemically clean in dilute sodium bisulfite or vinegar and replace the main piston. Reattach the main piston to the drive cap assembly. Reattach the regenerant piston (if needed) to the main piston. Do not lubricate the piston rod, main piston or regenerant piston.

Lubricant will adversely affect the red or clear lip seals. Reinsert the drive cap assembly and piston into the spacer stack assembly and hand tighten the drive cap assembly. Continue to tighten the drive cap assembly using a screwdriver as a ratchet until the black o-ring on the spacer stack assembly is no longer visible through the drain port. Excessive force can break the notches molded into the drive back plate. Make certain that the main drive gear still turns freely. The exact position of the piston is not important as long as the main gear drive turns freely.

Reattach the drive assembly to the control valve and connect all plugs. After completing any valve maintenance, press and hold NEXT and REGEN buttons for 3 seconds or unplug power source jack (black wire) and plug back in. This resets the electronics and establishes the service piston position. The display should flash all wording, then flash the software version (e.g. 154) then reset the valve to the service position.

SPACER STACK ASSEMBLY

To access the spacer stack assembly remove the drive assembly, drive cap assembly and piston. The spacer stack assembly can be removed easily without tools by using thumb and forefinger. Inspect the black o-rings and red or clear lip seals for wear or damage. Replace the entire stack if necessary. The spacer stack assembly has been 100% tested at the factory to insure proper orientation of one-way seals. Do not disassemble the stack.

The spacer stack assembly may be chemically cleaned (dilute sodium bisulfite or vinegar) or wiped with a soft cloth.

The spacer stack assembly can be pushed in to the control valve body bore by hand. Since the spacer stack assembly can be compressed it is easier to use a blunt object (5/8" to 1-1/8" in diameter) to push the center of the assembly into the control valve body. The assembly is properly seated when at least four threads are exposed (approximately 5/8") Do not force the spacer stack assembly in. The control valve body bore interior can be lubricated with silicone to allow for easy insertion of the entire stack. Do not use silicone or any other type of lubricant on the red or clear lip seals or the piston.

Reattach the drive cap assembly, and piston(s) and the drive assembly.

SERVICE INSTRUCTIONS CONTINUED

After completing any valve maintenance, press and hold NEXT and REGEN buttons for 3 seconds or unplug power source jack (black wire) and plug back in. This resets the electronics and establishes the service piston position. The display should flash all wording, then flash the software version (e.g. 154) and then reset the valve to the service position.

The plug and/or injector can be pried out with a small screwdriver. The plug can be wiped clean. If the plug leaks replace the entire plug. The injector consists of a throat and a nozzle. Chemically clean the injector with vinegar or sodium bisulfite. The holes can be blown out with air. Both pieces have small diameter holes that control the flow rates of water to insure that the proper concentration of regenerant is used. Sharp objects, which can score the plastic, should not be used to clean the injector. Scoring the injector or increasing the diameter of the hole could change the operating parameters of the injector. Two holes are labeled DN and UP. Check for compliance with one of the following:

- a. For downflow systems, the appropriate size injector is located in the "DN" hole, a plug is in the "UP" hole and the piston is a combination of the downflow main piston and the regenerant piston;
- b. For upflow systems, the appropriate size injector is located in the "UP" hole, a plug is in the "DN" hole and the piston is a combination of the upflow main piston and the regenerant piston; or
- c. For backwash only systems, a plug is in the "DN" hole and in the "UP" hole, and the piston only has a downflow main piston (the regenerant piston must be removed) and a plug is in the refill flow control position.

Push the plug(s) and/or injectors firmly in place, replace the screen and hand tighten the injector cap.

REFILL FLOW CONTROL ASSEMBLY OR REFILL PORT PLUG

To clean or replace the refill flow control, pull out the elbow-locking clip and then pull straight up on the elbow. Replace the elbow-locking clip in the slot so that it is not misplaced. Twist to remove the white flow control retainer. The flow control can be removed by prying upward through the side slots of the retainer with a small blade flat screwdriver.

Chemically clean the flow control or the white flow control retainer using dilute sodium bisulfite or vinegar. Do not use a wire brush. If necessary, replace the flow control o-ring on the flow control retainer, or the o-ring on the elbow.

Reseat the flow control so the rounded end is visible in the flow control. Reseat the white flow control retainer by pushing the retainer into the elbow until the o-ring seats. Remove locking clip, push down on elbow to reseat and insert locking clip.

Do not use Vaseline, oils, or other unacceptable lubricants on o-rings. A silicone lubricant may be used on the o-ring on elbow or the white retainer.

SERVICE INSTRUCTIONS CONTINUED

WATER METER OR METER PLUG

The water meter assembly is connected to the PC board by a wire. If the entire water meter assembly is to be replaced, remove the control valve cover and remove the power source and water meter plugs from the PC board. Unlatch the drive assembly and lean it forward. Unthread the water meter wire from the side of the drive assembly and through the drive back plate. To reinstall, rethread the water meter wire through the drive back plate and the side of the drive assembly. Reattach the drive assembly and the water meter and power plugs. If no water meter wire is visible, then a plug is installed and not a water meter. The water meter wire does not need to be removed from the PC board if the water meter is only being inspected and cleaned.

To remove the water assembly, unscrew the meter cap on the left side of the control valve. Pliers may be used to unscrew the nut if necessary. With the nut removed, a slot at the top of the water meter is visible. Twist a flat blade screwdriver in the slot between the control valve body and the meter. When the meter is part way out it is easy to remove the water meter from the housing. Once with water meter is removed from the control valve body, use your fingers to gently pull forward on the turbine to remove it from the shaft.

Do not use a wire brush to clean. Wipe with a clean cloth or chemically clean in dilute solution of bisulfite or vinegar. The turbine can be immersed in the chemical. Do not immerse electronics. If the turbine is scored or damaged, or the bearings on the turbine are worn, replace the turbine.

Do not lubricate the turbine shaft. The turbine shaft bearings are pre-lubricated. Do not use Vaseline, oils, or other unacceptable lubricants on the o-ring. A silicone lubricant may be used on the black o-ring.

Snap the turbine on the shaft and reinsert the water meter into the side slot. Hand tighten the nut. Do not use a pipe wrench to tighten nut.

BYPASS VALVE

The working parts of the bypass valve are the rotor assemblies that are contained under the bypass valve caps. Before working on the rotors, make sure the system is depressurized. Turn the red arrow shaped handles towards the center of the bypass valve and back to the arrow direction several times to ensure rotor is turning freely.

The nuts and caps are designed to be unscrewed or tightened by hand. If necessary a pair of pliers can be used to unscrew the nut or cap. Do not use a pipe wrench to tighten or loosen nuts or caps. Do not place screwdriver in slots on caps and/or tap with a hammer. To access the rotor, unscrew the cap and lift the cap, rotor and handle out as one unit. Twisting the unit as you pull it out will help to remove it more easily. There are three o-rings: one under the rotor cap, one on the rotor stem and the rotor seal. Replace worn o-rings. Clean rotor. Reinstall rotor.

When reinstalling the red arrow handles be sure that:

- 1 O-rings on both rotors face to the right when being viewed from the front of the control valve when the handle pointers are lined up with the control valve body arrows; or
- 2 Arrows point toward each other in the bypass position. Since the handles can be pulled off, they could be accidentally reinstalled 180° from their correct orientation. To install the red arrow handles correctly, keep the handles pointed in the same

direction as the arrows engraved on the control valve body while tightening the bypass valve caps. After completing, any valve maintenance, press and hold NEXT and REGEN buttons for 3 seconds or unplug power source jack (black wire) and plug back in. This resets the electronics and establishes the service piston position. The display should flash all wording then flash the software version (e.g. 154) and then reset the valve to the service position.

DRIVE CAP ASSEMBLY, DOWNFLOW PISTON, UPFLOW PISTON REGENERANT PISTON AND SPACER STACK ASSEMBLY

Drawing No.	Order No.	Description	Quantity
1	V3005	WS1 Spacer Stack Assembly	1
2	V3004	Drive Cap ASY	1
3	Back Plate	Refer to Programming and Cover Drawing Manual	1
4a	V3011*	WS1 Piston Downflow ASY	1
4b	V3011-01*	WS1 Piston Upflow ASY	
5	V3174	WS1 Regenerant Piston	1
6	V3135	O-ring 228	1
7	V3180	O-ring 337	1
8	V3105	O-ring 215 (Distributor Tube)	1
Not Shown	V3001	WS1 Body ASY Downflow	1
	V3001-02	WS1 Mixing Valve Body ASY	
	V3001UP	WS1 Body ASY Upflow	
	V3001-02UP	WS1 Mixing Valve Body Upflow ASY	

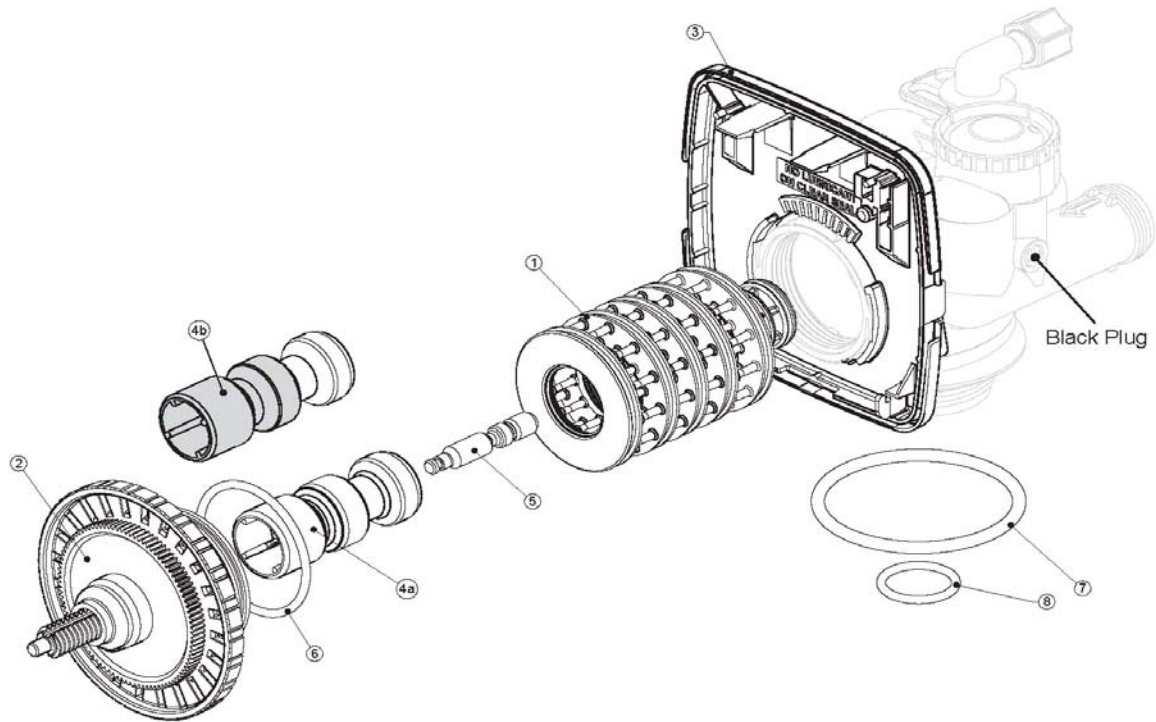

INJECTOR CAP, INJECTOR SCREEN, INJECTOR PLUG AND O-RING

Drawing No.	Order No.	Description	Quantity
1	V3176	Injector Cap	1
2	V3152	O-ring 135	1
3	V3177	Injector Screen	1
4	V3010-1Z	WS1 Injector ASY Z Plug	1
5	V3010-1A	WS1 INJECTOR ASY A BLACK	1
	V3010-1B	WS1 INJECTOR ASY B BROWN	
	V3010-1C	WS1 INJECTOR ASY C VIOLET	
	V3010-1D	WS1 INJECTOR ASY D RED	
	V3010-1E	WS1 INJECTOR ASY E WHITE	
	V3010-1F	WS1 INJECTOR ASY F BLUE	
	V3010-1G	WS1 INJECTOR ASY G YELLOW	
	V3010-1H	WS1 INJECTOR ASY H GREEN	
	V3010-1I	WS1 INJECTOR ASY I ORANGE	
	V3010-1J	WS1 INJECTOR ASY J LIGHT BLUE	
V3010-1K	WS1 INJECTOR ASY K LIGHT GREEN		
Not Shown	V3170	O-ring 011	*
Not Shown	V3171	O-ring 013	*

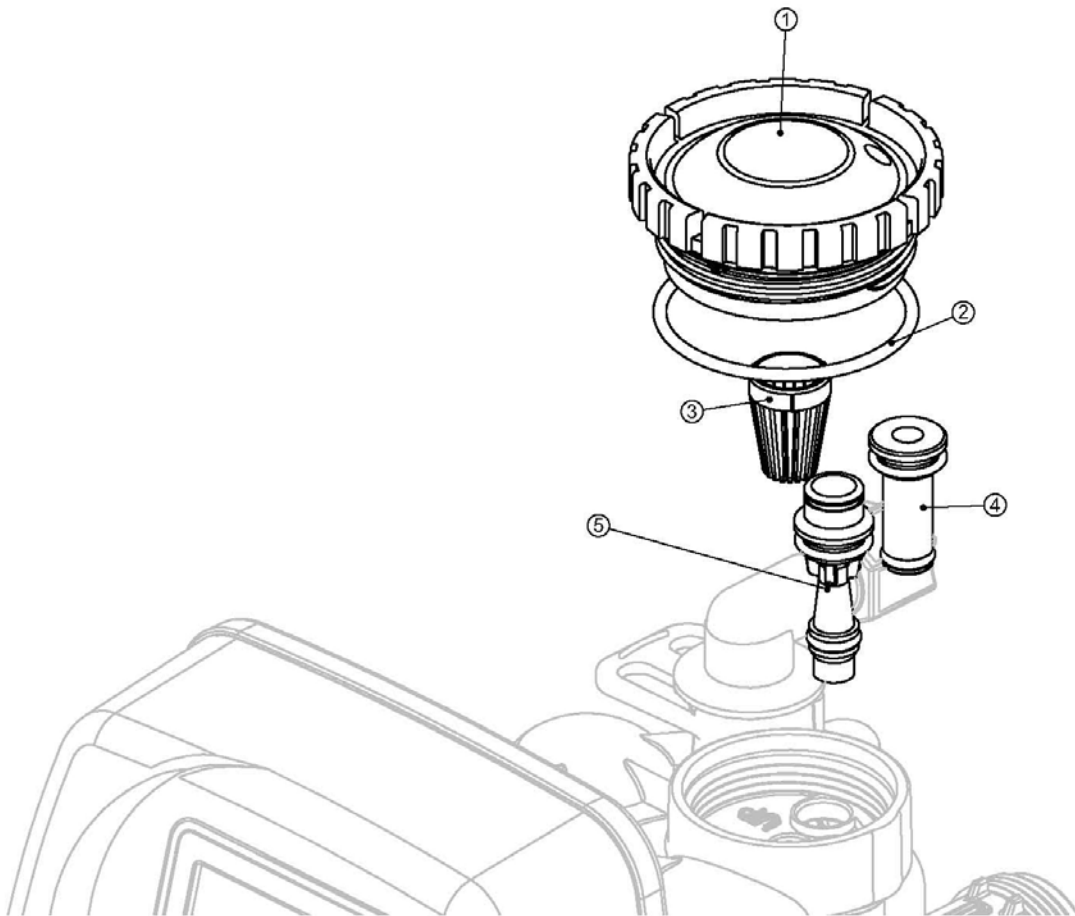

TROUBLESHOOTING

System Troubleshooting

PROBLEM	CAUSE	CORRECTION
1. Loss of Resin	A. Broken distribution tube	A. Replace distribution tube.
	B. Inlet/Outlet connection reversed.	B. Reconnect inlet/outlet connection properly.
2. Softener fails to regenerate.	A. Electrical service to unit has been interrupted.	A. Assure permanent electrical service (check fuse, plug, pull chain or switch.
	B. Timer is defective.	B. Replace timer.
	C. Power failure.	C. Reset time of day.
3. Hard Water	A. Bypass valve is open.	A. Close bypass valve.
	B. No salt in brine tank.	B. Add salt to brine tank and maintain salt level abovewater level.
	C. Injector screen plugged.	C. Clean injector screen.
	D. Insufficient water flowing into brine tank.	D. Check brine tank fill time and clean brine line flow control if plugged.
	E. Hot water tank hardness,	E. Repeated flushing of the hot water tank is required.
	F. Leak at distributor tube.	F. Make sure distributor tube is not cracked. Check "O" Ring and tube pilot.
	G. Internal valve leaking.	G. Replace seals and spacers and or piston.
4. Unit used too much salt.	A. Improper salt setting.	A. Check salt usage and sat setting.
	B. Excessive water in brine tank.	B. See Problem No. 8.
5. Loss of water pressure.	A. Iron buildup in line to water conditioner.	A. Clean line to water conditioner.
	B. Iron buildup in water conditioner.	B. Clear control and add mineral cleaner and increase regeneration frequency.
	C. Inlet of control plugged due to foreign material broken loose from pipes by recent work done on plumbing system.	C. Remove piston and clean control.
6. Loss of mineral through drain line.	A. Air in water system.	A. Assure that well system has proper air eliminator control. Check for dry well condition.
7. Iron in conditioned water.	A. Fouled mineral bed.	A. Check backwash, brine draw, and brine tank fill. Increase frequency of regeneration. Increase backwash time.

TROUBLESHOOTING

System Troubleshooting (continued)

PROBLEM	CAUSE	CORRECTION
8. Excessive water in brine tank.	A. Plugged drain line flow control.	A. Clean flow control.
	B. Plugged injector system.	B. Clean injector and screen.
	C. Foreign material in brine valve.	C. Replace timer.
	D. Defective controller.	D. Replace controller.
	E. Foreign material in brine line flow control.	E. Clean brine line flow control.
9. Softener fails to draw brine.	A. Drain line flow control is plugged.	A. Clean drain line flow control
	B. Injector is plugged.	B. Clean injector.
	C. Injector screen plugged.	C. Clean screen.
	D. Line pressure is too low.	D. Increase line pressure to 20 P.S.I.
	E. Internal control leak.	E. Change seals, spacers, and piston assembly.
10. Control cycles continuously.	A. Broken or shorted switch,	A. Determine if switch or timer is faulty and replace it, or replace complete power head.
11. Drain flows continuously.	A. Piston is not positioned correctly when in service.	A. Check timer program and positioning of control. Replace power head assembly if not positioning properly.
	B. Foreign material in control.	B. Remove power head assembly and inspect bore. Remove foreign material and check control in various regeneration positions.
	C. Internal control leak	C. Replace seals and piston assembly.
12. Brine tank fills during brine step.	A. Clogged drain.	A. Replace drain line.
	B. Internal piston seal leaks.	B. Replace seals in piston assembly.

TROUBLESHOOTING

Troubleshooting Programming

PROBLEM	POSSIBLE CAUSE	SOLUTION
1. Timer does not display time of day	a. Transformer unplugged	a. Connect power
	b. No electric power at outlet	b. Repair outlet or use working outlet.
	c. Defective transformer	c. Replace transformer
	d. Defective PC board	d. Replace PC board
2. Timer does not display correct time of day	a. Switched outlet	a. Use uninterrupted outlet
	b. Power outage	b. Reset time of day
	c. Defective PC board	c. Replace PC board
3. No softening display when water is flowing	a. Bypass valve in bypass position	a. Put bypass valve in service position
	c. Restricted/stalled meter turbine	c. Remove meter and check for rotation or foreign material
	d. Defective meter	d. Replace meter
	e. Defective PC board	e. Replace PC board
4. Control valve regenerates at wrong time of day of day	a. Power outages	a. Reset control valve to correct time
	b. Time of day not set correctly	b. Reset to correct time of day
	c. Time of regeneration incorrect	c. Reset regeneration time
	d. Control valve set at "on 0" (immediate regeneration)	d. Check control valve set-up procedure regeneration time option
	e. Control valve set at NORMAL on 0	e. Check control valve set-up procedure regeneration time option
5. ERROR followed by code number Error Code 1001 -Unable to recognize start of regeneration Error Code 1002 - Unexpected stall Error Code 1003 - Motor ran to long, timed out trying to reach next cycle position Error Code 1004 - Motor ran to long, timed out trying to reach home position If other Error Codes display contact the factory.	a. Control valve has just been serviced	a. Press NEXT and REGEN for 3 seconds or unplug power source Jack (black wire) and plug back in to reset control valve
	b. Foreign matter is lodged in control valve.	b. Check piston and spacer stack assembly for foreign matter.
	c. High drive forces on piston	c. Replace piston(s) and spacer stack assembled.
	d. Control valve piston not in home position	d. Press NEXT and REGEN for 3 seconds or unplug power source jack (black wire) and plug back in to reset control valve
	e. Motor not inserted fully to engage pinion, motor wires broken or disconnected, motor failure	e. Check motor and wiring. Replace motor if necessary
	f. Drive gear label dirty or damaged missing or broken gear	f. Replace or clean drive gear
	g. Drive bracket incorrectly aligned to back plate	g. Reseat drive bracket properly
	h. PC board is damaged or defective	h. Replace PC board
	i. PC board incorrectly aligned to drive bracket	i. Ensure PC board is correctly snapped on to drive

CONTENTS

Troubleshooting Programming (continued)

PROBLEM	POSSIBLE CAUSE	SOLUTION
6. Control valve stalled in regeneration	a. Motor not operating	a. Replace motor
	b. No electric power at outlet	b. Repair outlet or use working outlet
	c. Defective transformer	c. Replace transformer
	d. Defective PC board	d. Replace PC board
	e. Broken drive gear or drive cap assembly	e. Replace drive gear or drive cap assembly
	f. Broken piston retainer	f. Replace drive cap assembly
	g. Broken main or regenerant piston	g. Replace main or regenerant piston
7. Control valve does not regenerate when REGEN button is pressed.	a. Transformer unplugged	a. Connect transformer
	b. No electric power at outlet	b. Repair outlet or use working outlet
	c. Broken drive gear or drive cap	c. Replace drive gear or drive cap assembly
	d. Defective PC board	d. Replace PC board
8. Control valve does not regenerate automatically but does when REGEN button is depressed	a. By-pass valve in bypass position	a. Put control valve in service position
	b. Meter connection disconnected	b. Connect meter to PC board
	c. Restricted/stalled meter turbine	c. Remove meter and check for rotation or foreign matter
	d. Defective meter	d. Replace meter
	e. Defective PC board	e. Replace PC board
	f. Set-up error	f. Check control valve set-up procedure
9. Time of day flashes on and off	a. Power has been out more than two hours, the transformer was unplugged and then plugged back into the wall outlet, the transformer plug was unplugged and then plugged back into the board or the NEXT and REGEN buttons were pressed to reset the valve.	a. Reset the time of day

Distributed by:



Peerless, Inc.
1701 East Vine Street
P.O. Box 3615
Kalamazoo, MI 49003
Phone: (269) 344-6137
Fax: (269) 344-2894
www.peerlesswater.com

Revised 4-2013